

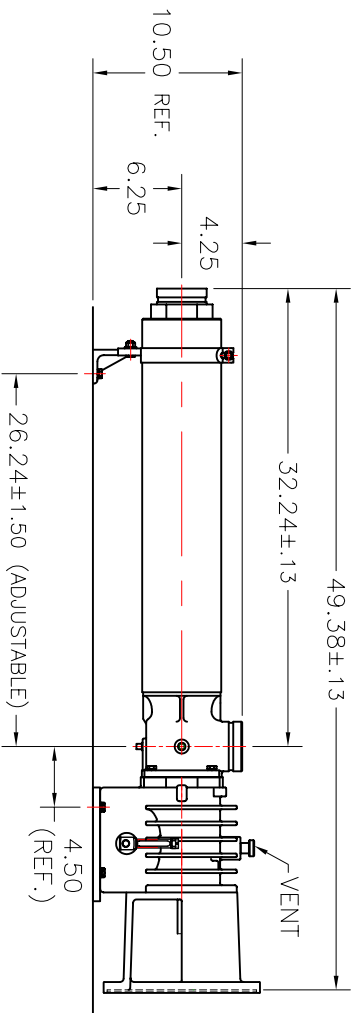

- NOTES:
1. DIMENSIONS ARE IN INCHES.
 2. INLET CONNECTION MATES WITH 3" VICTAULIC TYPE CLAMPED UNION.
 3. DISCHARGE CONNECTION MATES WITH 3" VICTAULIC TYPE CLAMPED UNION.
 4. **SPECIAL MECHANICAL MODIFICATIONS MAY SUPERCEDE DIMENSIONS WHICH ARE A FUNCTION OF THE MODIFICATION.**
 5. DIMENSIONS RELATED TO OR DEPENDENT ON MOTOR ARE BASED ON STANDARD EFFICIENCY TEFC 215TS C-FACE SIEMENS MOTOR.
 6. FOR PUMPS REQUIRING DIFFERENT FRAME SIZES THAN SHOWN, CONTACT FACTORY FOR DIMENSIONS.
 7. SEE PUMP INSTRUCTION FOR ADDITIONAL INSTALLATION, START-UP, AND MAINTENANCE INFORMATION.

TONKAFLO
SS5512KZB

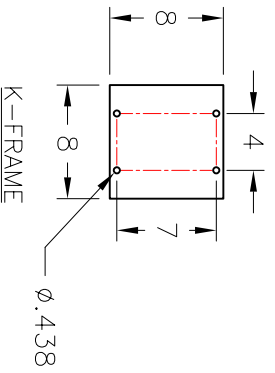
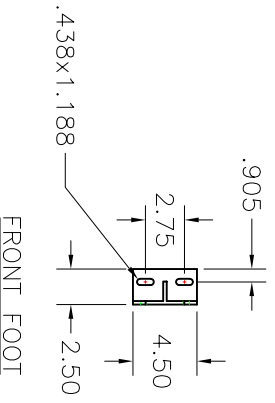
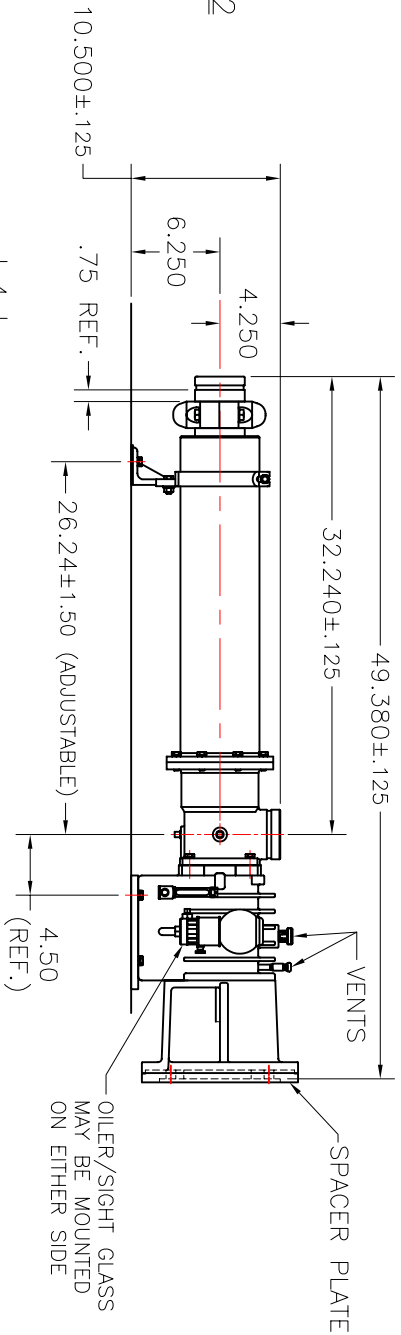

T&T NH76K4F12



		T&T Pump Co., Inc. FAIRHONT, WV 26554	
		DRAWING TITLE NH76K4F12 TO SS5512KZB LAYOUT COMPARISON	
UNLESS OTHERWISE NOTED LINEAR DIMS. IN INCHES TOLERANCES DECIMAL .xxx+/- FINEST .xxx+/- ANGULAR DO NOT SCALE DRAWING	DRAWN CWR 7-14-09	CAD file NH76K4F12 TO SS5512KZB LAYOUT	SCALE nom
CHECK DESIGN ENGR	RELEASE DATE 7-14-09	SHEET 1 of 1	SHEET 1 of 1