

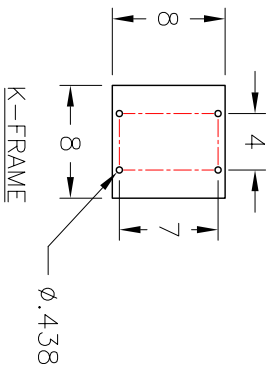

- NOTES:
1. DIMENSIONS ARE IN INCHES.
  2. INLET CONNECTION MATES WITH 3" VICTAULIC TYPE CLAMPED UNION.
  3. DISCHARGE CONNECTION MATES WITH 3" VICTAULIC TYPE CLAMPED UNION.
  4. **SPECIAL MECHANICAL MODIFICATIONS MAY SUPERGEDE DIMENSIONS WHICH ARE A FUNCTION OF THE MODIFICATION.**
  5. DIMENSIONS RELATED TO OR DEPENDENT ON MOTOR ARE BASED ON STANDARD EFFICIENCY TEFC 215TS C-FACE SIEMENS MOTOR.
  6. FOR PUMPS REQUIRING DIFFERENT FRAME SIZES THAN SHOWN, CONTACT FACTORY FOR DIMENSIONS.
  7. SEE PUMP INSTRUCTION FOR ADDITIONAL INSTALLATION, START-UP, AND MAINTENANCE INFORMATION.

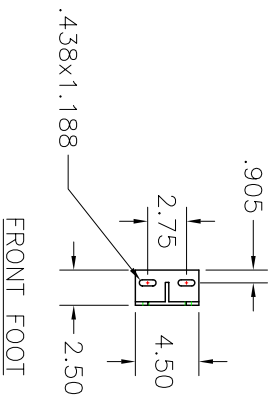
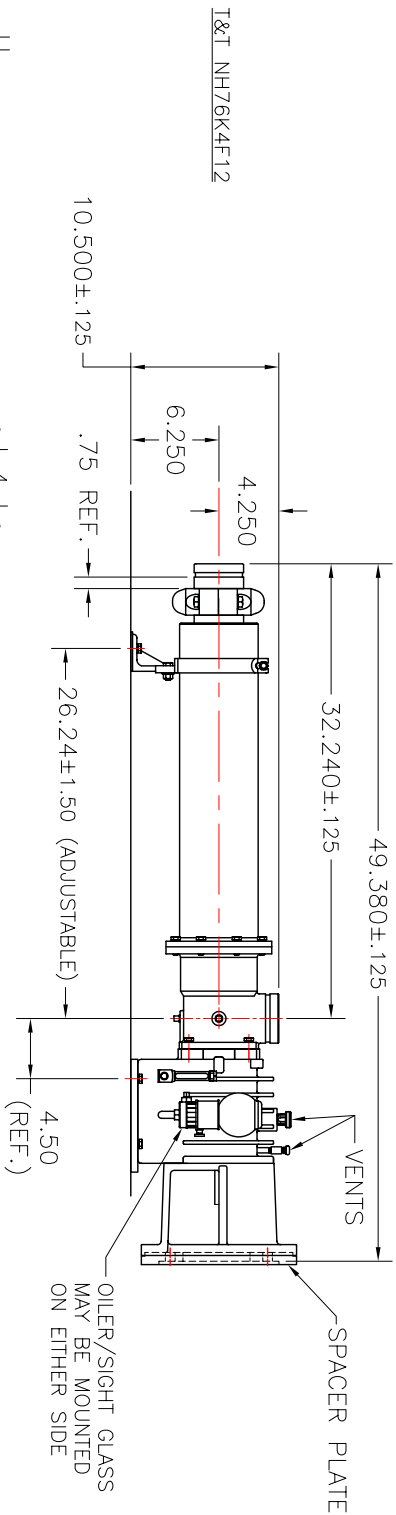
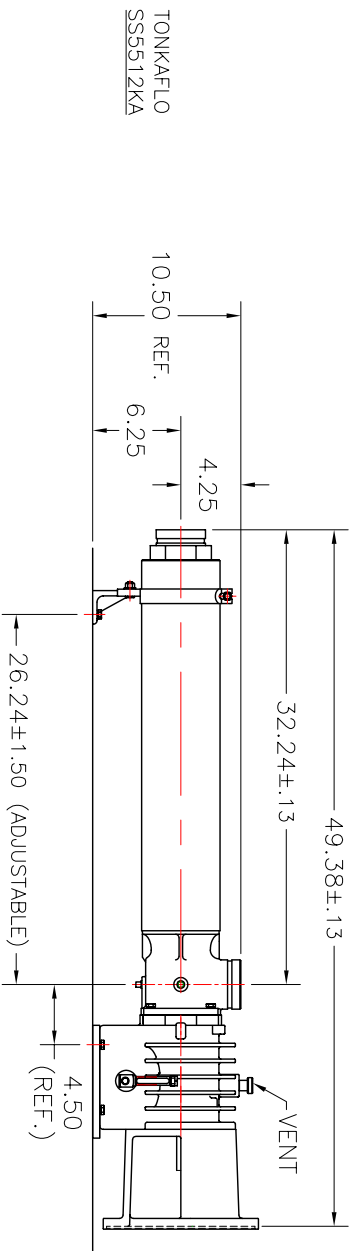

		UNLESS OTHERWISE NOTED	
		LINEAR DIMS. IN INCHES	
TOLERANCES DECIMAL		FINISH	
.xxx+/-		ANGULAR	
.xxx+/-		+/-	
DO NOT SCALE DRAWING			
Drawing no.			
DRAWN		CWR	
CHECK		8-04-08	
DESIGN			
ENR			
DRAWING TITLE		T&T Pump Co. Inc. FAIRHONT, WV 26554	
NH76K4F12 TO SS5512KA			
LAYOUT COMPARISON			
Dwg size		CAD file	
A		NH76K4F12 TO SS5512KA LAYOUT	
SCALE non-RELEASE DATE 8-05-08 Sheet 1 of 1			